

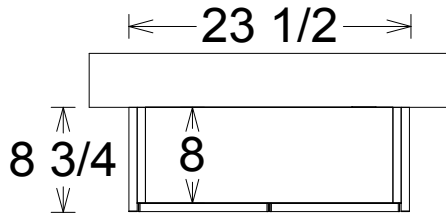

PHONE: (905) 832-8311
 FAX: (905) 832-0732

US2024 SQUARE FRONTS



PLAN VIEW

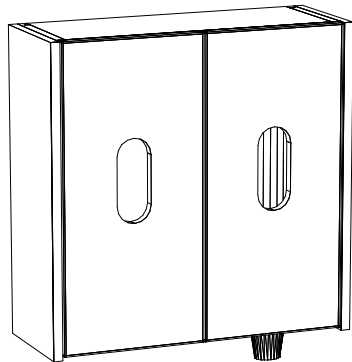

ISOMETRIC VIEW

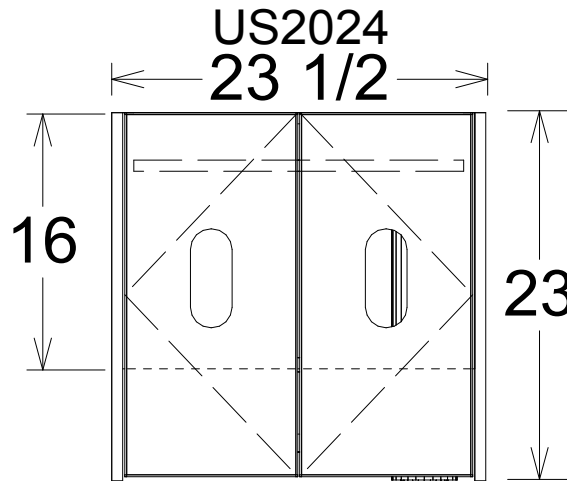

GLOVE, CUP &
 TOWEL DISP.

ELEVATION

[Redacted]
 [Redacted]
 [Redacted]

P.O.#
 W/O#
 START DATE:
 ORDER DATE:
 APPROX. SHIP:
 SET UPS: 1
 TOP COLOUR:
 -
 CAB COLOUR:
 -
 TOE KICK = ST. STEEL
 HANDLES: 5" CHROME

 PVC EDGE:
 HARDWARE: SOFT CLOSE DOORS
 FULL EXTENSION
 SOFT CLOSE DRAWERS
 SKETCH #: UQ23624-Q03

OPTIONS INCLUDED:
 MP-8 CUP DISP.
 MP-12 TOWEL DISP.
 GD01 GLOVE BOX INSERT

I CONFIRM THIS ORDER TO BE CORRECT: _____
 DEALER AUTHORIZED SIGNATORY / DATE

NOTE: PLUMBING & ELECTRICAL SPECS WILL BE PROVIDED AT THE TIME OF ORDER

REVISIONS		REVISIONS	
EM	13 JAN 2015	-	-
-	-	-	-
-	-	-	-